

REAL-TIME  
CONCENTRATION  
MONITORING OF  
FAB CHEMICALS

**K-PATENTS**  
PROCESS INSTRUMENTS



SEMICON PROCESS REFRACTOMETER PR-23-MS

# APPLICATIONS

K-Patents Semicon Process Refractometer PR-23-MS monitors real-time the consistency of liquid chemical concentrations throughout the whole semiconductor fabrication process, i.e. from chemical supplies down to fab in-line and tool in-situ chemicals quality control.

## BULK CHEMICAL SUPPLIES

Changes in chemical quality can occur during in-house handling and storage. PR-23-MS activates an alarm if the chemical is not within pre-set specifications and prevents wrong chemicals or wrong concentrations from entering the process.

## PHOTORESIST DEVELOPMENT

The photoresist developer concentration has a significant influence on the photoresist development step. An appropriate concentration of the developer should be maintained to comprise both the fabricating throughput and the pattern resolution. PR-23-MS can be used for real-time developer concentration monitoring instead of the traditional wafer-to-wafer or run-to-run methods.

## PHOTORESIST STRIPPING

As stripping of most photoresists is an acid/base neutralization process, the speed and quality of photoresist stripping can be optimized by PR-23-MS when the strength of overall alkalinity is known.

## WET ETCHING

As temperature and concentration of the etching solution have major impact on the wet etch rates, various etching processes can be optimized and etch end points determined when the chemical concentration is known. For instance, the KOH etch process can be optimized when the composition of heated KOH/H<sub>2</sub>O solution is continuously monitored with PR-23-MS.

## POST ETCH WAFER CLEANING

PR-23-MS measures the concentration of expensive cleaning chemicals and polymer removals, such as EKC-265 in the post etch wafer cleaning. This provides a real-time indication of the bath and assists in increasing the bath lifetime and wafer pass in, and in reducing the chemical consumption.

## CHEMICAL MECHANICAL PLANARIZATION (CMP)

PR-23-MS provides a method for concentration monitoring of acids and chemicals, such as HF or HCl in the CMP abrasive slurries. This information can be used to determine the end point and to achieve a better uniformity of the planarization process.

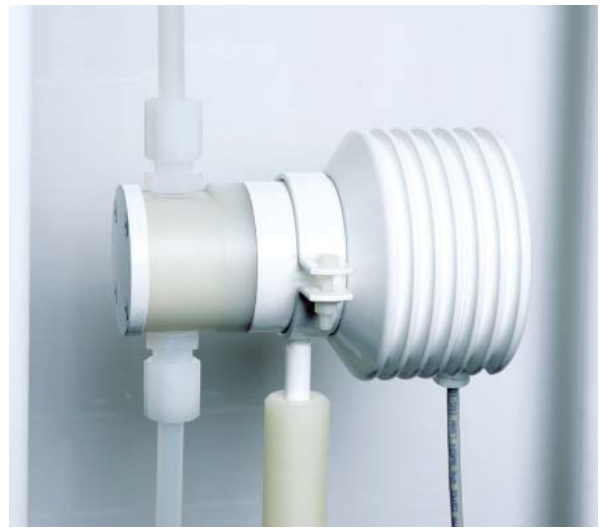

## TYPICAL MONITORED CHEMICALS AND MIXTURES:

Acetic acid CH<sub>3</sub>COOH, Acetone CH<sub>3</sub>COCH<sub>3</sub>, Ammonia NH<sub>4</sub>OH, Ammonium fluoride NH<sub>4</sub>F, Ammonium hydroxide NH<sub>4</sub>OH, Ammonium sulphate (NH<sub>4</sub>)<sub>2</sub>SO<sub>4</sub>, Citric acid C<sub>6</sub>H<sub>8</sub>O<sub>7</sub>, Chromic acid CrO<sub>3</sub>, Dilute Hydrofluoric acid DHF, Ferric chloride FeCl<sub>2</sub>, Formic acid HCO<sub>2</sub>H, Hydrofluoric acid HF, Hydrochloric acid HCl, Hydrogen peroxide H<sub>2</sub>O<sub>2</sub>, Isopropylalcohol IPA, Magnesium chloride MgCl<sub>2</sub>, Nickel chloride NiCl<sub>2</sub>, Nitric acid HNO<sub>3</sub>, Phosphoric acid H<sub>3</sub>PO<sub>4</sub>, Potassium hydroxide KOH, Sodium chloride NaCl, Sodium hydroxide NaOH, Sulphuric acid H<sub>2</sub>SO<sub>4</sub>, Tetramethylammonium hydroxide TMAH (CH<sub>3</sub>)<sub>4</sub>NOH

RCA1, SC1 (APM), SC2, RCA2, EKC265, ACT930, ACT970 etc.

## REAL-TIME MONITORING

K-Patents key area of expertise over the past 25 years has been applying in-line refractive index measurement technique to industrial process control applications.

K-Patents Semicon Process Refractometer PR-23-MS is designed specifically for the semiconductor industry. It is physically small and easy to install in the bulk chemicals supply lines, and in the point of use chemical blending, mixing, dilution and spiking applications.

The PR-23-MS provides a continuous 4-20 mA or digital measurement signal, which offers many possibilities for real-time monitoring and applied process control.

For example, low and high concentration alarms can be configured to prevent wrong liquids reaching the fabrication process and thus avoid costly production problems and equipment damage. The technology also assists in reducing wafer scrap, optimizing chemical consumption and improving environmental performance of chemicals waste management.

PR-23-MS has a typical accuracy of 0.1% by weight, e.g. for a HCl in water. For multicomponent solutions, the measurement signal works as a check-sum.

PR-23-MS is an all purpose transmitter, in the sense that the same instrument monitors all kinds of liquid chemicals. Yet, it is as simple to use and install as e.g. a temperature transmitter.

## SENSOR MOUNTING

The PR-23-MS is mounted directly in-line without filtering. The compact design allows integration in a wet bench or in a cabinet and the need for foot print area is very low.

The PR-23-MS has a built-in flow cell designed to keep all metal and corroding parts from coming into contact with the process liquid. All the wetted surfaces are made of non-metallic materials, either PTFE (Teflon®) or PVDF (Kynar®). The prism material is spinel or sapphire.

The measurement is not influenced by particles, air or gas bubbles, or turbulent flow and impurities in the ppm range.

Vertical line

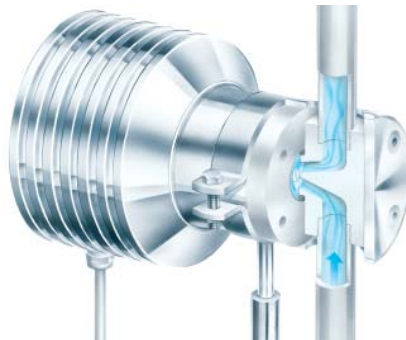

Horizontal line

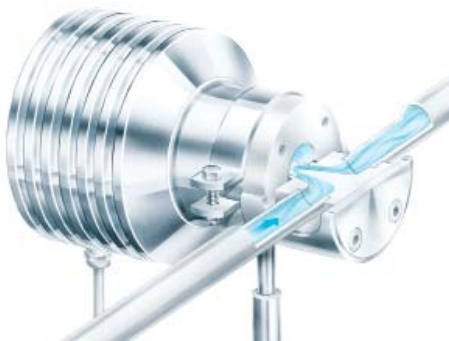

## REMOTE USABILITY

The PR-23-MS ease-of-use is significantly improved by a built-in web server that can be accessed via Ethernet. It is possible to obtain a remote display with real-time measurement data and diagnostics, and remotely alter instrument configuration settings or update program versions without having to go to the field.

Only a cross-over cable and data acquisition software are needed for collecting the data from a PR-23-MS refractometer. The communication is built on standard protocols (UDP/IP) and K-Patents offers ready-to-install software for the data acquisition.

The K-Patents data acquisition software is expandable in case the user wants to modify the program. The program is written in Java and is therefore system independent. It can be tailored to almost any computing environment.

# DIGITAL MEASUREMENT PRINCIPLE

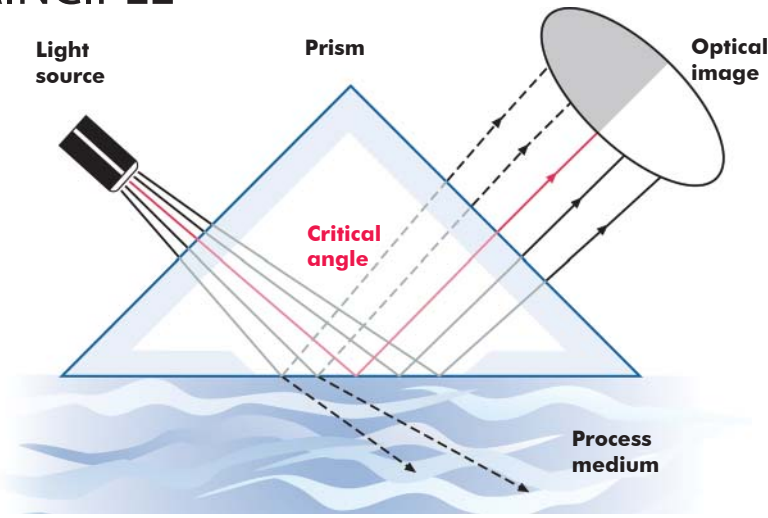

The light source sends light against the interface between the prism and the process solution, where the rays meet the surface at different angles.

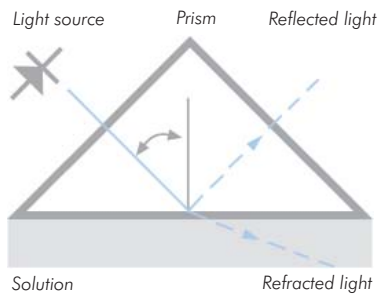

Depending on the angle, some rays are totally reflected. Some rays are only partially reflected, and most of the light is refracted into the process solution.

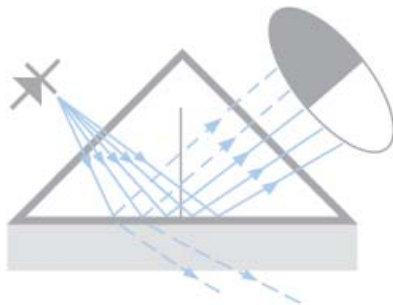

Thus an optical image with a dark sector and a light sector is created.

The angle corresponding to the shadow line is called the Critical Angle of Total Reflection. The Critical Angle is a function of the refractive index and hence the concentration of the solution.

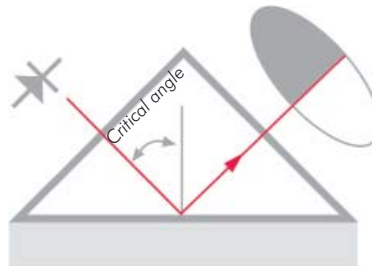

A digital CCD-camera detects the optical image and the shadow line. The camera transforms the optical image point-by-point to an electrical signal. The exact shadow line position is located and converted to a reading in refractive index.

A built-in temperature sensor measures the temperature close to the interface of the process liquid. The indicating transmitter converts the refractive index and temperature to

The diagnostics program ensures that the measurement is reliable.

# DRIFT-FREE CALIBRATION

K-Patents PR-23-MS has no calibration drift and it needs no maintenance, adjustment or recalibration over time.

The sensor is factory calibrated to measure refractive index  $n_D$  and temperature  $T$  in standard units. Each sensor has identical calibration  $n_D = 1.32 \dots 1.53$  (corresponding to 0-100% b.w.). One or two sensors can be connected to one Indicating transmitter.

Because the sensors have identical calibration, and each sensor gives Refractive Index  $n_D$  and temperature as output, the same instrument can monitor all kinds of liquid chemicals. Also all sensors can be freely interchanged without optical calibration or parameter changes.

Each sensor comes with a calibration certificate comparing a set of standard liquids to the actual sensor output. The calibration and accuracy can be easily verified on-site with certified refractive index liquids and K-Patents menu guided verification procedure.

# DESIGN

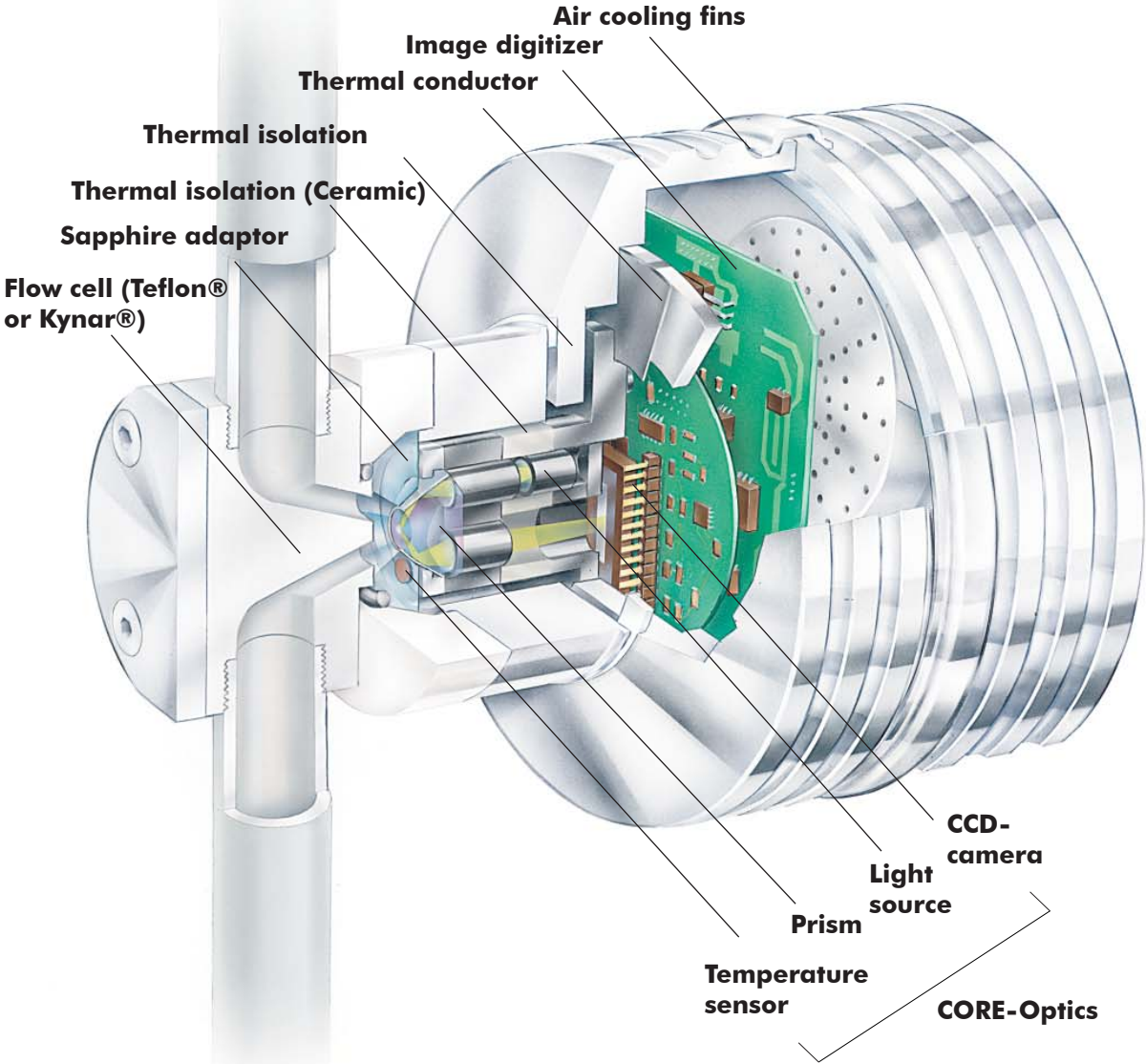

K-Patents PR-23-MS advances the patented CORE-optics (Compact Optical Rigid Element) module that is isolated from the sensor body. The COPE-optics secures the measuring components from any influence of pressure, flow or temperature changes.

(US Patent Nos. US6067151 and US6760098 B2, German Patent No. DE19855218).

# SPECIFICATIONS

## SENSOR PR-23-MS

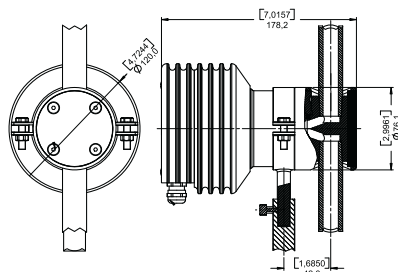

## INDICATING TRANSMITTER DTR

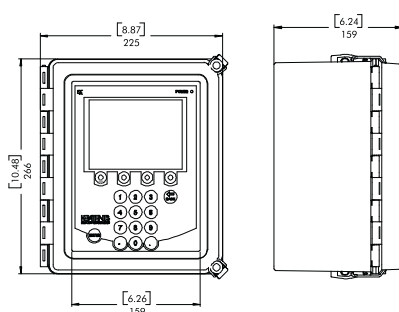

Refractive Index range, standard:	Full range, $n_D = 1.3200 \dots 1.5300$ (corresponds to 0...100% b.w.), spinel prism
Refractive Index range, option:	$n_D = 1.2600 \dots 1.5000$ , sapphire prism (for Hydrofluoric acid, HF)
Accuracy:	R.I. $\pm 0.0002$ (corresponds typically to $\pm 0.1\%$ b.w.). Repeatability and stability correspond to accuracy.
Speed of response:	1s undamped, damping time selectable up to 5 min
Patented CORE-Optics:	No mechanical adjustments and digital measurement with 3648 pixel CCD element, 589 wavelength sodium D-line light emitting diode (LED), built-in Pt-1000 temperature sensor (linearization according to IEC 751)
Temperature compensation:	Automatic, digital compensation
Instrument verification:	With standard R.I. liquids and K-Patents documented procedure (ISO 9000)
SENSOR PR-23-MS:	Process connection with 1/2" (F) Thread G; 1/2" (F) NPT; 1/4"...1" Pillar and Flare fitting
Sensor wetted parts:	Teflon® PTFE or Teflon® PFA or Kynar® PVDF or AISI 316 L stainless steel as option, prism gasket Teflon®, prism spinel (standard), O-ring Kalrez, adaptor sapphire
Sensor weight:	5.5 kg (12 lbs)
Process temperature:	-20°C (-4°F)...150°C (300°F)
Ambient temperature:	Sensor: min. -20°C (-4°F), max. 45°C (113°F) Indicating transmitter: min. 0°C (32°F), max. 50°C (122°F)
Sensor housing:	AISI 316 L stainless steel, epoxy coated sensor cover
Sensor protection class:	IP67, Nema 4
Approvals for hazardous locations:	ATEX approved for Zone II, area classification EX II 3 G EEx nA II T4 / FM approved for Class I, Div. 2, Groups A, B, C & D / CSA certified for Class I, Div. 2, Groups A, B, C and D, T4
Approval for electrical safety:	cCSAus certified for Sensor: Class I, Poll. Deg. 3; Transmitter: Class I, Poll. Deg. 2; Install. Cat. II.
Patents:	US Patents US6067151 and US6760098B2, German Patent DE19855218
<b>INDICATING TRANSMITTER DTR:</b>	
Display:	320x240 pixel graphical LCD with LED backlight, keypad with 8 membrane keys
Current output:	Two independent current outputs, 4-20 mA, max. load 1000 Ohm, galvanic isolation 1500 VDC or AC (peak), hold function during prism wash
Ethernet connection:	10/100 Mbit/s, data acquisition over UDP/IP Protocol with data acquisition software
Power:	AC input 100-240 VAC/50-60 Hz, optional 24 VDC, 30 VA
Alarms/Wash relays:	Two built-in signal relays, max. 250 V/3 A
Sensor connectivity:	One or two sensors can be connected to one DTR. Sensors independent with own parameter sets and usable in different applications. Two current outputs configurable independently to indicate process concentration or temperature of either sensor.
Remote functions:	Remote display and access to real-time measurement values, diagnostic messages, altering configuration and parameter settings, and up-grading program versions via Ethernet connection.
Indicating transmitter weight:	4.5 kg (10 lbs)
Transmitter protection class:	Enclosure IP66, Nema 4X
INTERCONNECTING CABLE:	IEC 61158-2 compliant two-wire cable
Interconnecting cable length:	Standard 10 m (33 ft), max. 200 m (660 ft)
OPTIONS:	Cable fittings to Indicating transmitter: European cable glands M20x1.5 or US conduit hubs

ORDERING INFORMATION:	- Sensor wetted parts material	- Process pipe size
	- Sensor process connection	- Process flow rate
	- Desired scale	- Supply voltage and frequency
	- Properties of process solution	- Options and accessories
	- Process temperature range	

K-PATENTS OY  
P.O. BOX 77  
ELANNONTIE 5  
FIN-01511 VANTAA, FINLAND  
PHONE: INT.+358-9-8256 640  
FAX: INT.+358-9-8256 6460  
INFO@KPATENTS.COM  
WWW.KPATENTS.COM

K-PATENTS, INC.  
1804 CENTRE POINT CIRCLE, SUITE 106  
NAPERVILLE, IL 60563  
U.S.A.  
PHONE: (630) 955 1545  
FAX: (630) 955 1585  
INFO@KPATENTS-USA.COM  
WWW.KPATENTS.COM

We reserve right to technical alterations.