

Mark	Rev.	Date	Rev. by	Appr.
A	Installation angle changed	2.3.07	HS	HS

SIDE VIEW

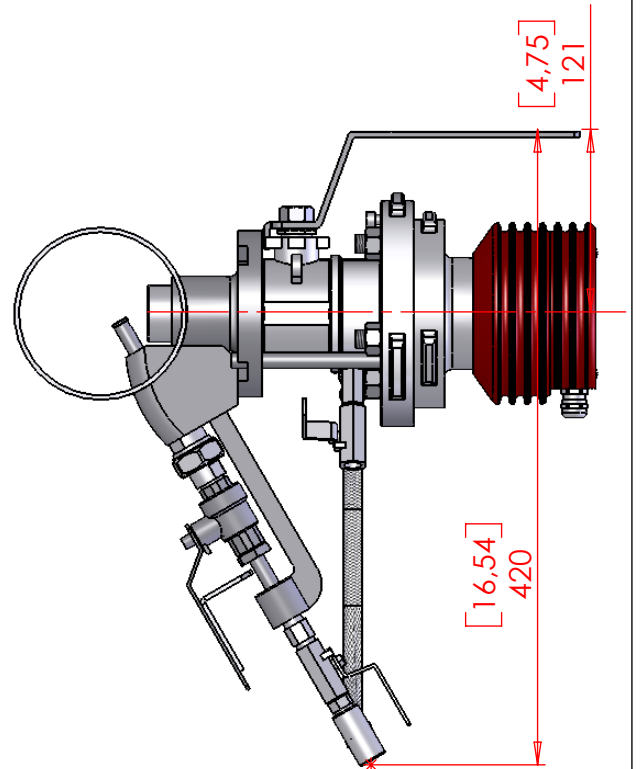

TOP VIEW

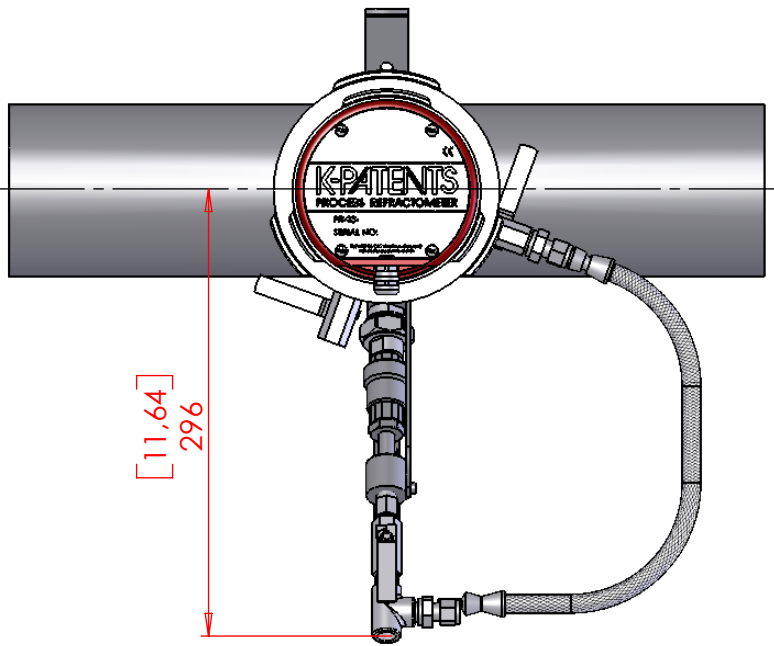
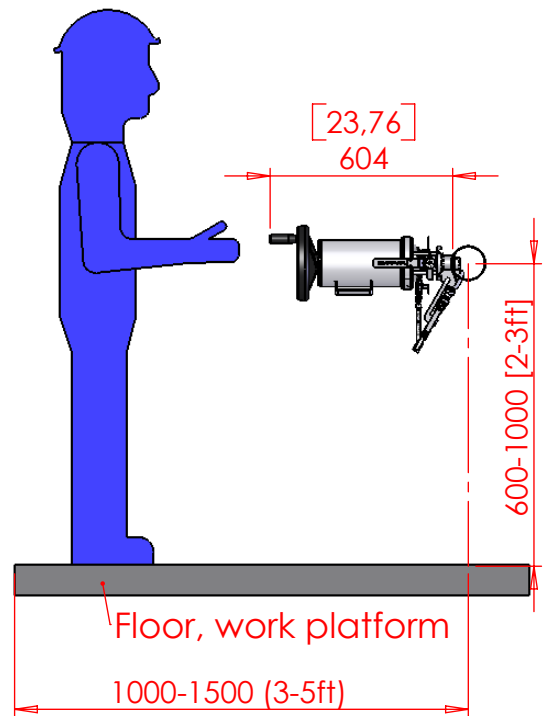
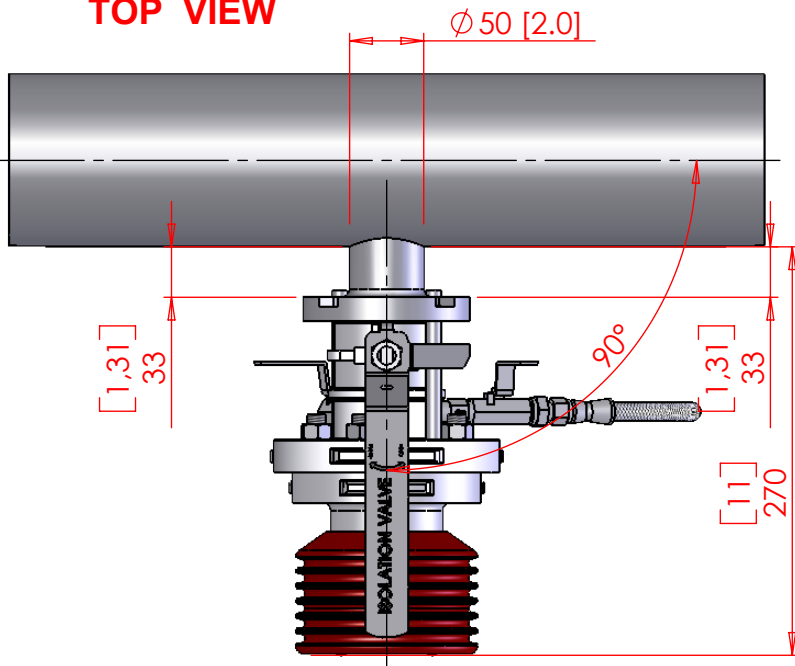

Part no.	Drawing no.	Title/Name, designation	Standard	Dimensions, model no.	Quantity
General tolerances SFS 4011 FINE	Scale 1 : 4	Join MRP0000	File MTG471.DRW	Material	
			Drawing description PR-23-SD horizontal pipe mounting		
			Drawing number MTG471/A	Drawn 31.3.06 HS	Appr. 31.3.06 HS