

Mark	Rev.	Date	Rev. by	Appr.
A	Check valve changed	20.9.06	HS	HS

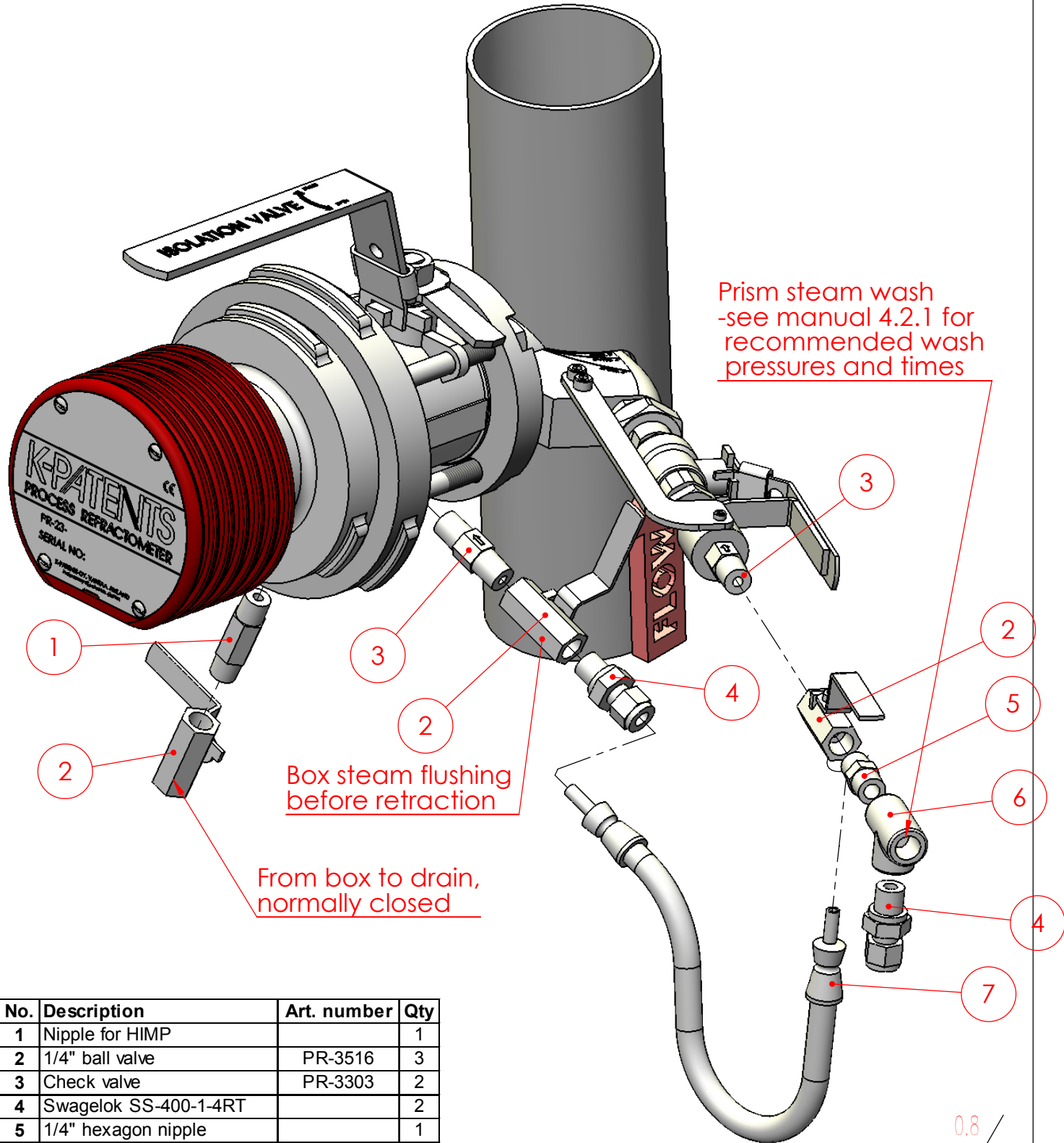

No.	Description	Art. number	Qty
1	Nipple for HIMP		1
2	1/4" ball valve	PR-3516	3
3	Check valve	PR-3303	2
4	Swagelok SS-400-1-4RT		2
5	1/4" hexagon nipple		1
6	1/4" T-piece		1
7	Flexible pipe SS-4BHT-12		1

Part no.	Drawing no.	Title/Name, designation	Standard	Dimensions, model no.	Quantity
General tolerances	Scale	Join	File	Material	
SFS 4011 FINE	1 : 3	MRP0000	MTG470.drw		
			Drawing description		
			PR-23-SD Steam pipe fittings mounting		
Drawing number			Drawn		
MTG470/A			30.3.06 HS		
			Appr.		
			30.3.06 HS		