

Mark	Rev.	Date	Rev. by	Appr.

Item no.	Name	Material	Supplied by	Pcs.
1	Sensor PR-23-AP-TSS	AISI316L	K-Patents	1
2	Sanitary clamp 2.5"	AIS304	K-Patents	1
3	Sanitary gasket 2.5"	EPDM	K-Patents	1
4	Sanitary ferrule 2.5"	AISI316L	K-Patents	1
5	Customer pipe/vessel	AISI316L	Customer	1

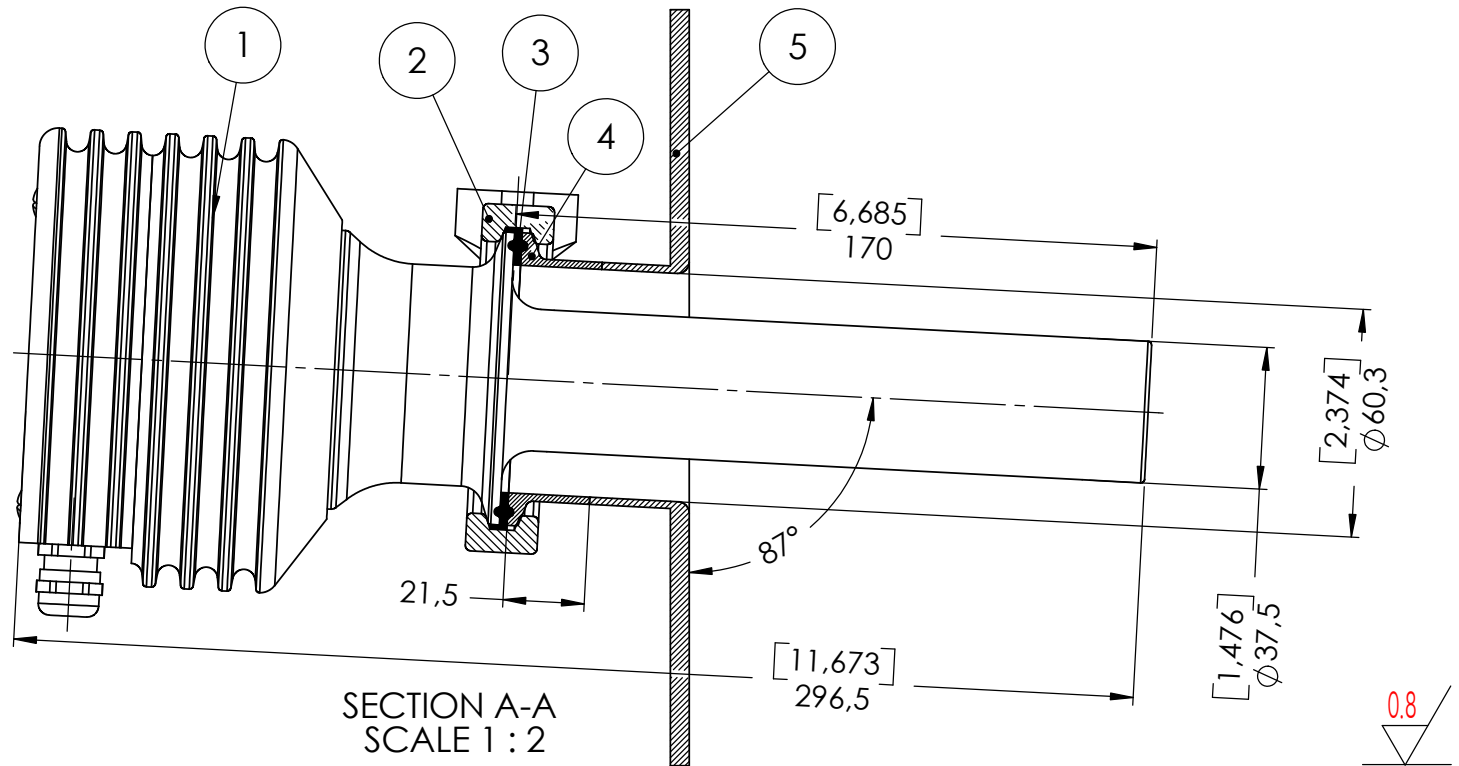
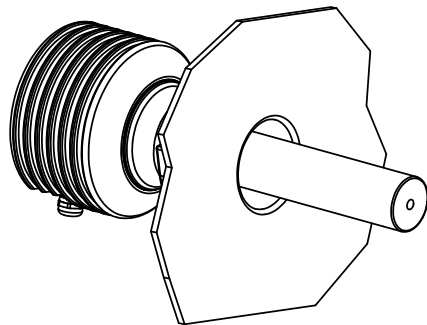
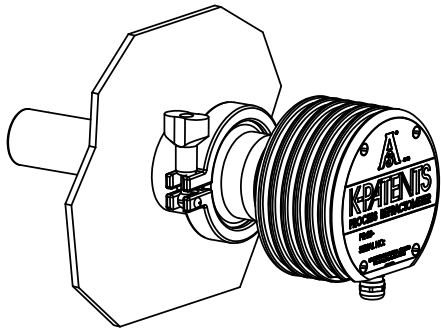

Part no.	Drawing no.	Title/Name, designation	Standard	Dimensions, model no.	Quantity
----------	-------------	-------------------------	----------	-----------------------	----------

General tolerances SFS 4011 FINE	Scale 1 : 2	Join MRP0000	File MTG442.drw	
-------------------------------------	----------------	-----------------	--------------------	--

K-PATENTS
PROCESS INSTRUMENTS

Drawing description
Mounting drawing PR-23-AP-TSS

Drawing number MTG442	Drawn 28.2.2005 HS
	Appr. 28.2.2005 HS