

Mark	Rev.	Date	Rev. by	Appr.

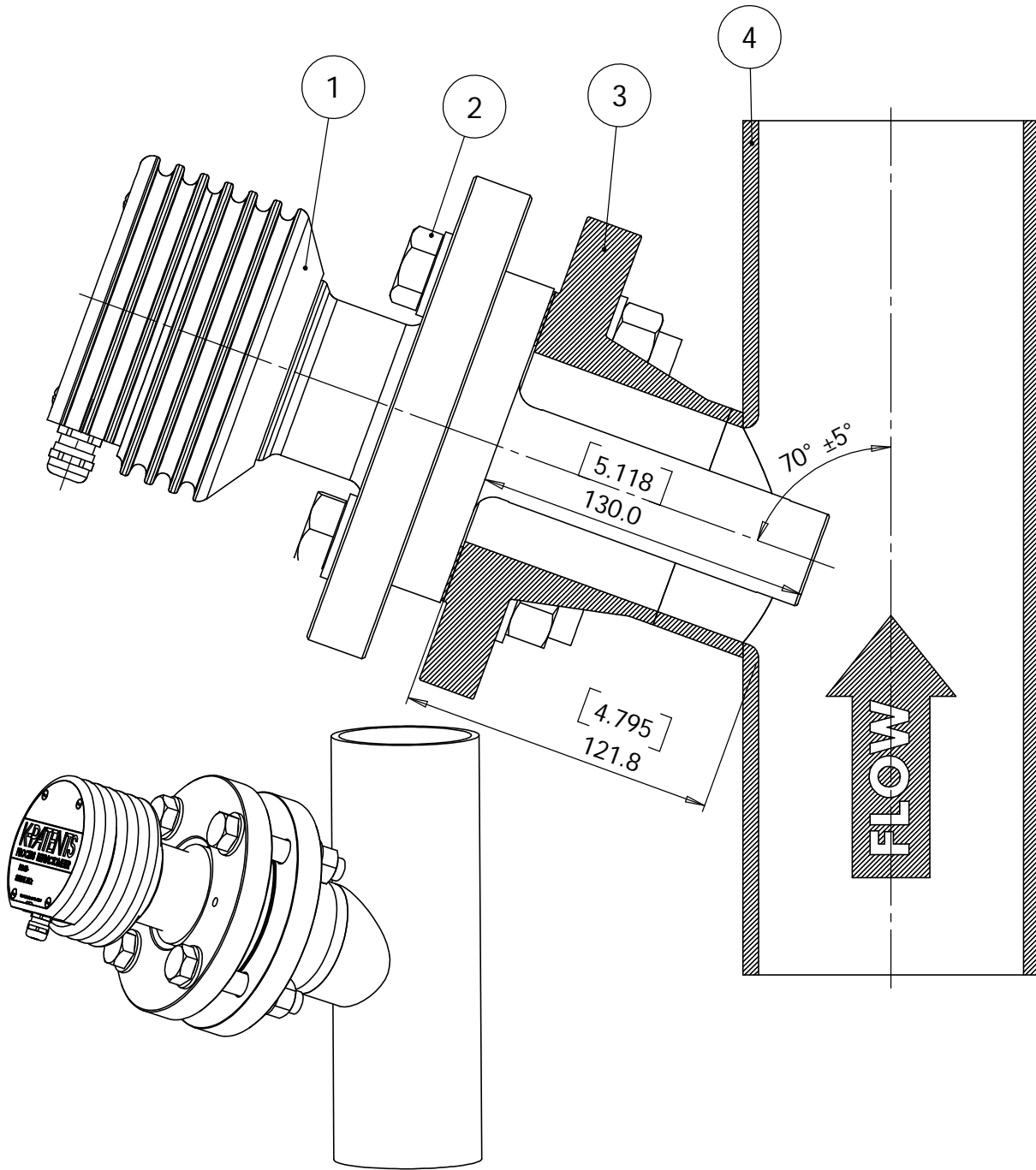

ITEM NO.	DESCRIPTION	MATERIAL	SUPPLIED BY	QTY/PCS.
1	PR-23-GP-DSS/ASS/JSS sensor		K-Patents	1
2	Bolt, washer, nut	AISI316L	Customer	4/8
3	Welding neck flange DN 80 or ANSI 3"	AISI316L	Customer	1
4	Customer pipe DN80/3" or larger	AISI316L	Customer	1

Part no.	Drawing no.	Title/Name, designation	Standard	Dimensions, model no.	Quantity
General tolerances	Scale	Join	File	Material	
	2:5		MTG432		

**K-PATENTS**  
PROCESS INSTRUMENTS

Drawing description  
PR-23-GP-DSS/ASS/JSS sensor mounting to  
DN80/ 3" or larger pipe

Drawing number  
MTG432

Drawn 16.9.04 HS  
Appr. 16.9.04 HS