

Mark	Rev.	Date	Rev. by	Appr.
A	Check valve supplier changed	5.9.06	HS	HS

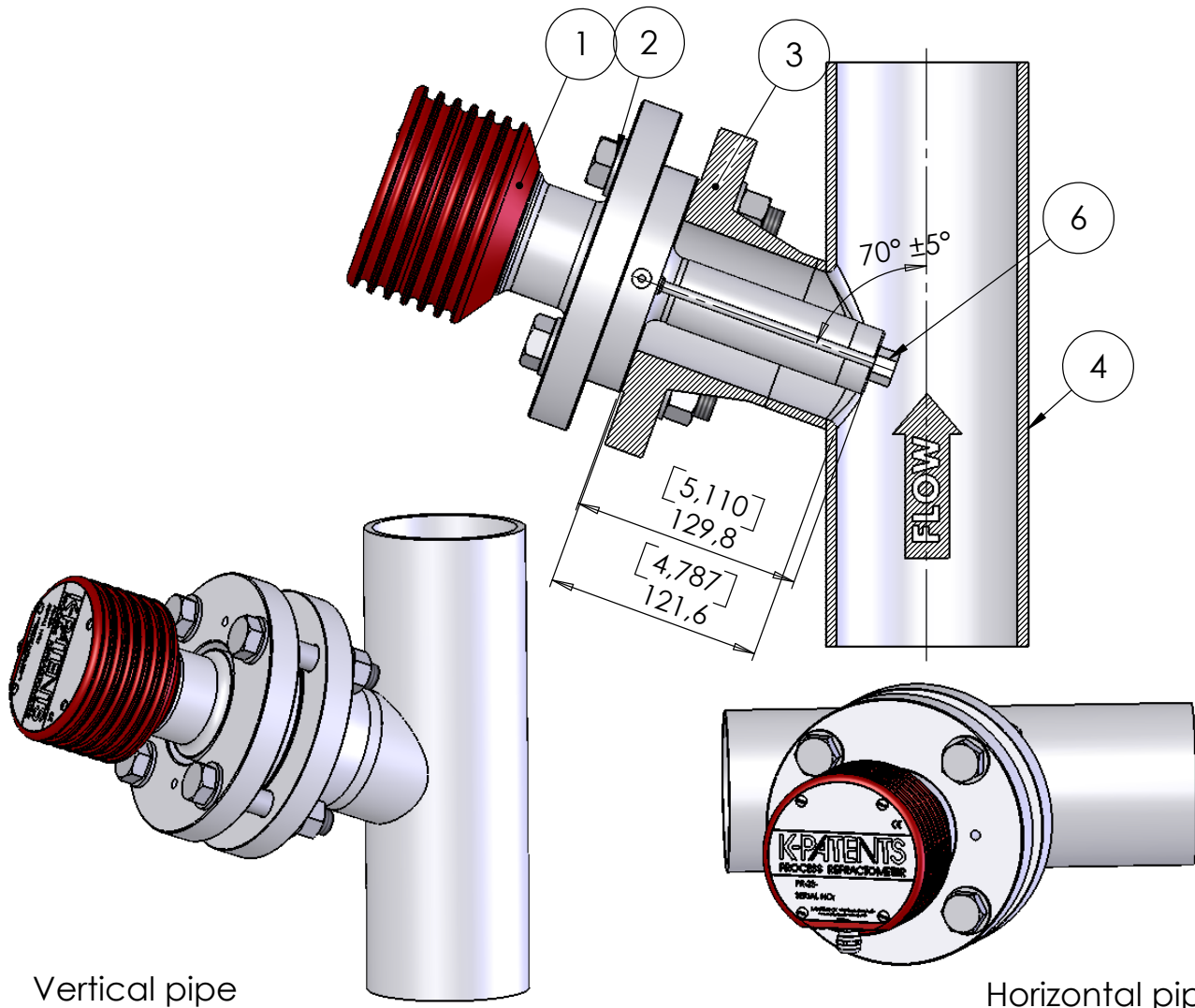

ITEM NO.	DESCRIPTION	MATERIAL	SUPPLIED BY	PCS.
1	PR-23-GP-DSS/ASS/JSS sensor		K-Patents	1
2	Bolt, washer, nut	AISI316L	Customer	4/8
3	Welding neck flange DN80 or ANSI3"	AISI316L	Customer	1
4	Customer Pipe DN80/3" or larger	AISI316L	Customer	1
5	Check valve PR-3302	AISI316L/Kalrez	Customer	1
6	PR-23-GP wash nozzle		K-Patents	1
6.1	Steam nozzle PR-9324	AISI316L	K-Patents	
6.2	Water Nozzle PR-9323	AISI316L	K-Patents	1
6.3	Pressurized water nozzle PR-9325	AISI316L	K-Patents	1

Part no.	Drawing no.	Title/Name, designation	Standard	Dimensions, model no.	Quantity
General tolerances	Scale 1:4	Join	File MTG420.drw	Material	

K-PATENTS
PROCESS INSTRUMENTS

Drawing description
PR-23-GP-DSS/ASS/JSS-WN/WP/SN mounting to
DN80/3" or larger pipe

Drawing number
MTG420/A

Drawn 16.9.04 HS
Appr. 16.9.04 HS