

FOR SAFE FIRING
OF BLACK LIQUOR
IN RECOVERY BOILERS

K-PATENTS
PROCESS INSTRUMENTS



K-PATENTS DIGITAL DIVERT CONTROL SYSTEM DD-23

APPLICATION



SAFE OPERATION OF RECOVERY BOILERS REQUIRES K-PATENTS DIGITAL DIVERT SYSTEM

Feeding low concentrations of black liquor solids to a kraft chemical recovery boiler burner can cause a steam explosion. A digital divert control system is required to ensure safe operation.

The Black Liquor Recovery Boiler Advisory Committee (BLRBAC) recommends standards for safe firing of black liquor and suggests using an automatic black liquor divert control system to ensure that weak liquor is not fed into the boiler.

BLRBAC requires that if the black liquor concentration falls below 58%, the system shall give an audible alarm signal, and go to a diversion function to direct the black liquor flow to by-pass the boiler. A concentration value of 60% shall give an audible alarm to notify the users about the low concentration. Furthermore, the control unit shall check that the difference between the two individual refractometer signals does not exceed 2%.

These close tolerances require digital circuitry which eliminates drift.



BLRBAC SYSTEM

The K-Patents digital divert control system DD-23 complies strictly with all recommendations of BLRBAC.

The DD-23 system includes two SAFE-DRIVE™ Process refractometer sensors in the main black liquor line, and two Indicating transmitters and a Divert control unit in an integrated panel.

As an added benefit, each refractometer is a completely independent measurement system. Each system sends a separate mA output signal, which can be used by a control system or a DCS.

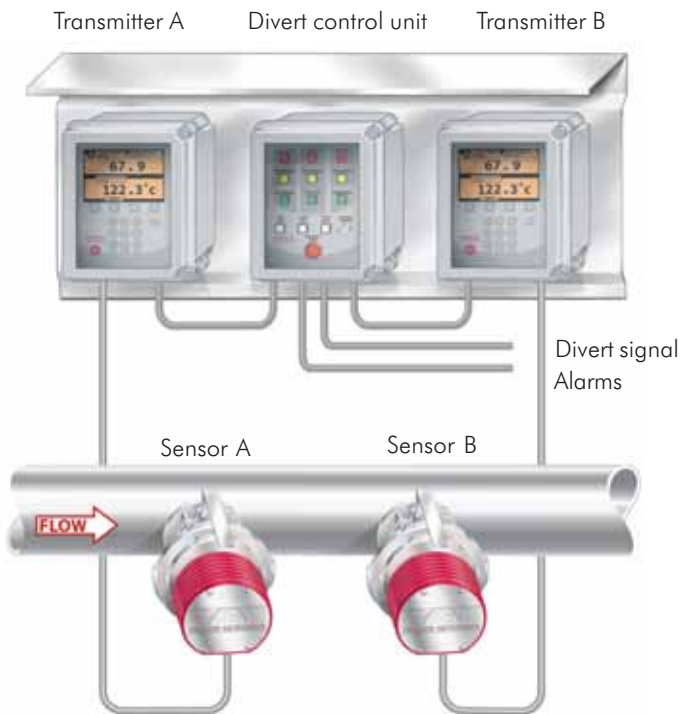

ALL-DIGITAL DESIGN ELIMINATES FALSE DIVERT ALARMS

The K-Patents divert control system DD-23 is completely microprocessor controlled. The digital signal transmission and microprocessor implemented diagnostics ensure error free operation. The system eliminates false alarms, because it reacts only when the level of solids truly falls below the safe limit. K-Patents DD-23 helps avoid costly process shut-downs resulting from unwarranted divert actions.

There is a separate power supply for each refractometer.

RETRACTABLE SAFE-DRIVE™ SENSOR

The K-Patents SAFE-DRIVE™ Process refractometer sensor is installed with SAFE-DRIVE™ Isolation valve (Patent pending) that allows for safe and easy insertion and retraction of the refractometer under full operating pressure without having to valve off the liquor piping or having to shut down the process. The SAFE-DRIVE™ Isolation valve contains a steam wash system for automatic prism cleaning.

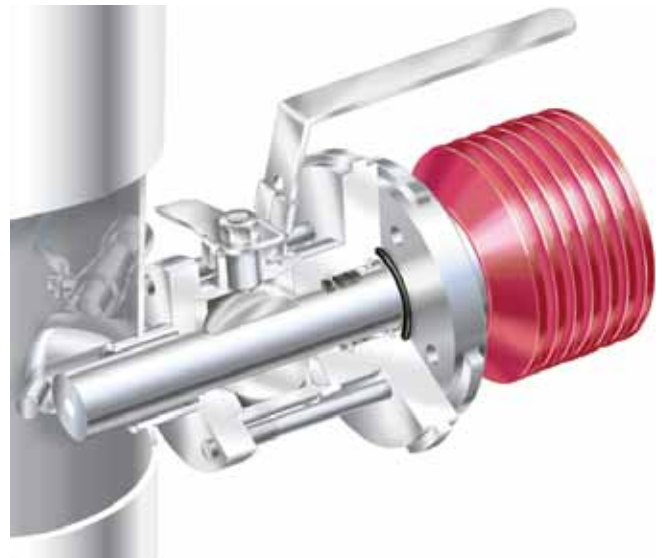

THE UNIQUE SAFETY ASPECTS OF THE SAFE-DRIVE™ ARE:

- Accidental opening or closing of the ball valve is prevented.
- Easy-to-place and self-retaining design for safe insertion and retraction.
- The casing secures the user from accidental spills during the insertion and retraction.
- Triple sealing by two lip seals and an O-ring.
- The retractable prism wash nozzle can be safely removed for service checks.

DIVERT DECISION LOGICS

1. ALARMS

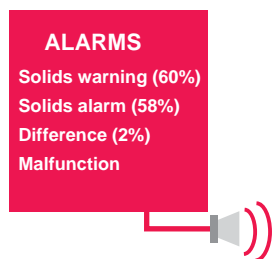

The divert decision is controlled by the divert control unit. The built-in logic provides three levels of decision rules for tight control.

The first control level contains four alarms indicating the following:

- Black liquor solids warning at 60%; notifies the user about the low concentration
- Black liquor solids alarm at 58%.
- Refractometer difference; the signal between the two individual refractometers must not exceed 2%.
- Refractometer malfunction alarm; is initiated, if a refractometer is malfunctioning.

2. STATUS OF REFRACTOMETERS

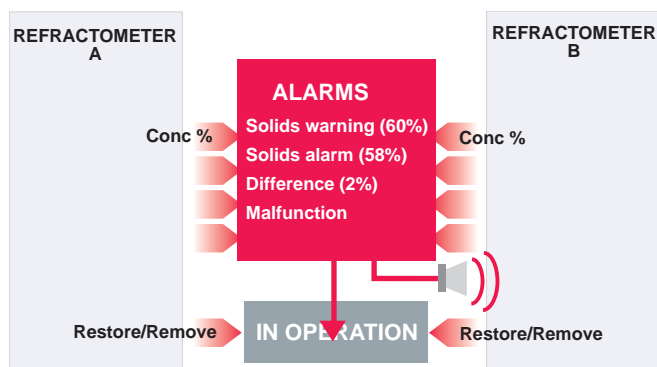

The second control level controls the status of each refractometer. The solids warning, the solids alarm and refractometer malfunction alarm are initiated by either refractometer A or B. The divert control unit checks that the difference between the two individual refractometer signals does not exceed 2%.

Unnecessary and false divert alarms are avoided by the following interlocks:

- A refractometer can initiate an alarm only when it is operating.
- Alarm for refractometer malfunction can only be initiated if both refractometers are operating.

3. DIVERT DECISION

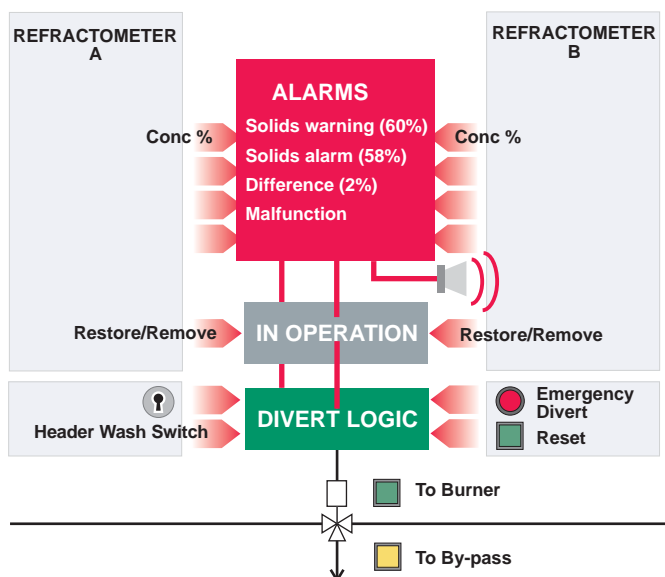

Due to the built-in intelligent diagnostics, the status of each refractometer is tightly controlled in the divert operation. A malfunctioning refractometer is automatically removed from operation.

The third control level consists of the actual divert decision rules. According to these rules the black liquor flow is directed either to the burner or to the by-pass line.

With the Emergency Divert button the divert can be manually initiated in an override or in an emergency situation. The Reset button resets the divert action.

For increased safety, there is a lockable override function. The override function is only available when the Header Wash Switch is activated.

REMOTE FUNCTIONS

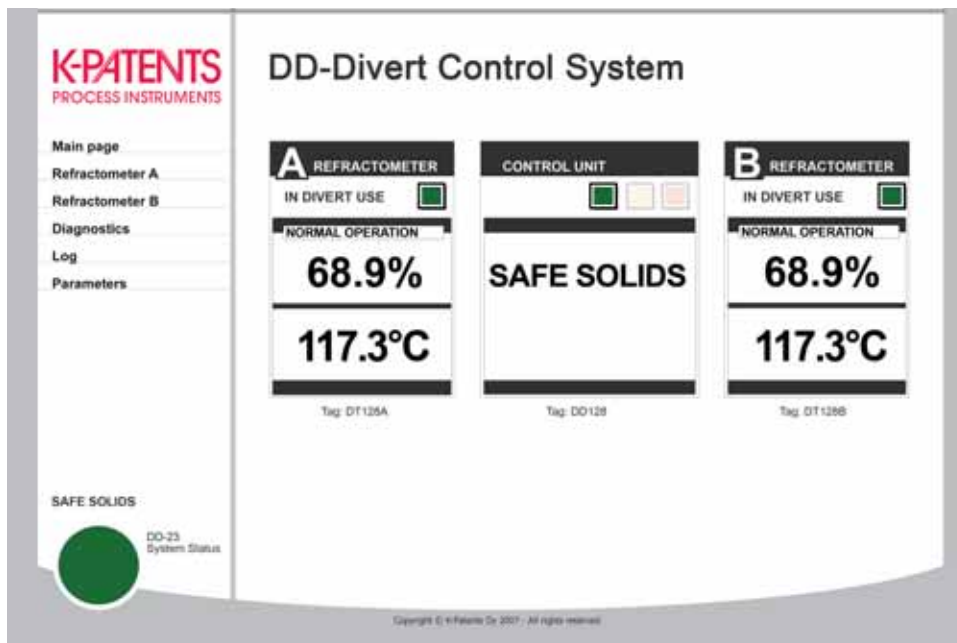

EVENT DATA LOGGING

All signals and communication in the DD-23 system are digital and therefore can be used for data logging and remote monitoring via Ethernet.

The DD-23 records a full history of event data such as emergency diverts, divert resets, warnings, alarms, parameter and configuration changes, malfunction data and the states and changes of external contact inputs.

REMOTE MONITORING

The DD-23 has a built-in web server that brings a compact and easy-to-use remote display to the control room. This enables centralized management of all divert system data using a standard web browser.

The remote display features real-time measurement values and diagnostic information, system and instrument status, warnings and alarms, and full event log records.

SPECIFICATIONS

K-Patents DD-23 Digital Divert Control System fully complies with all principles of Recommended Good Practice for Safe Firing of Black Liquor in Black Liquor Recovery Boilers by BLRBAC.

DD-23 SYSTEM COMPONENTS:

Two K-Patents SAFE-DRIVE™ Process Refractometers PR-23-SD (A and B) with Isolation ball valves SDI-23 and with automatic prism wash system.

DD Divert Control Unit including an operator panel and control logics. Provides contact outputs for warnings and alarms and inputs for system control.

The indicating transmitters and the divert control unit are mounted in a stainless steel roofed mounting plate. Wiring between the transmitters and the control unit is included.

SAFE-DRIVE™ Retractor tool SDR-23 for safe sensor insertion and retraction.

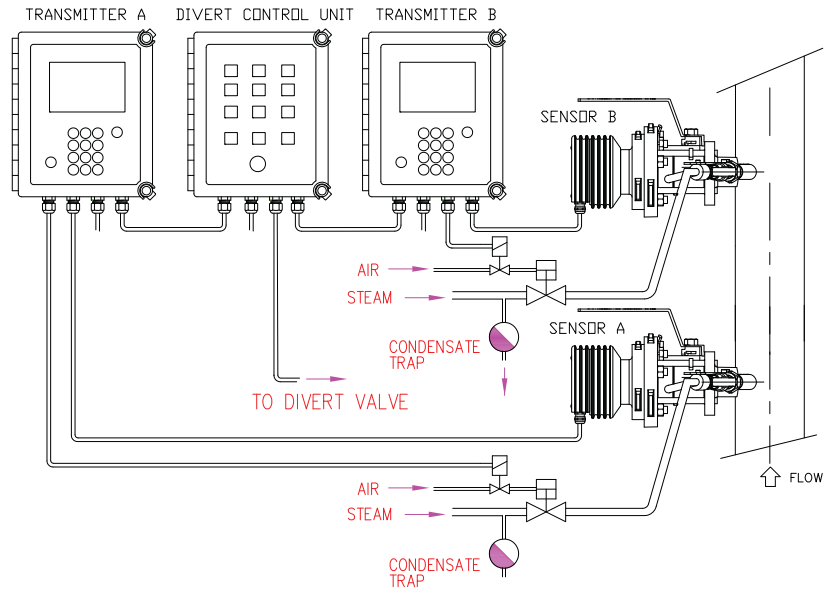

DD-23 SYSTEM FEATURES:

Refractometer measurements:	The refractometers provide separate mA measurement signals that are independent of the divert control system.
Isolation valve process connection:	By welding to pipe sizes of 2"-24" or via a spool piece (diameter of 2"-20"). Can be mounted on either horizontal or vertical pipe lines.
Spool piece process connection option:	DIN-flange PN25/ANSI-flange 150 lbs.
Prism wash:	Automatic prism wash system with steam, complete with nozzle and two check valves; one for prism wash, one for stuffing box flush. The steam wash nozzle is retractable and can be removed for service check.
Alarms and contact functions:	Warning and alarm relays for low solids and refractometer difference. Relays for instrument and system status. Header wash switch. Contact inputs for external divert switch and hard-wired divert reset.
Event log:	All user actions, system status changes, parameter changes, alarms, and warnings are recorded into an event log. The full event log is available through the remote display; a compact version can be viewed on the transmitter.
Remote functions:	Remote monitoring using a standard web browser. Data of real-time measurement, divert condition, measurement values, diagnostic messages and event log records remotely available to control room via Ethernet connection.

ORDERING INFORMATION:

Desired scale, properties of process solution	Desired process connection	Sensor mounting position (horizontal or vertical)
Process temperature and pressure range	Length of interconnecting cables	Options and accessories
Process flow range and pipe diameter	Supply voltage and frequency	

K-PATENTS, INC.
 1804 CENTRE POINT CIRCLE
 SUITE 106, NAPERVILLE
 IL 60563, U.S.A.
 PHONE: (630) 955 1545
 FAX: (630) 955 1585
 INFO@KPATENTS-USA.COM
 WWW.KPATENTS.COM

K-PATENTS OY
 P.O. BOX 77
 ELANNONTIE 5
 FIN-01511 VANTAA, FINLAND
 PHONE: INT.+358-9-8256 640
 FAX: INT.+358-9-8256 6461
 INFO@KPATENTS.COM
 WWW.KPATENTS.COM

We reserve right to technical alterations.