

Phenol Process

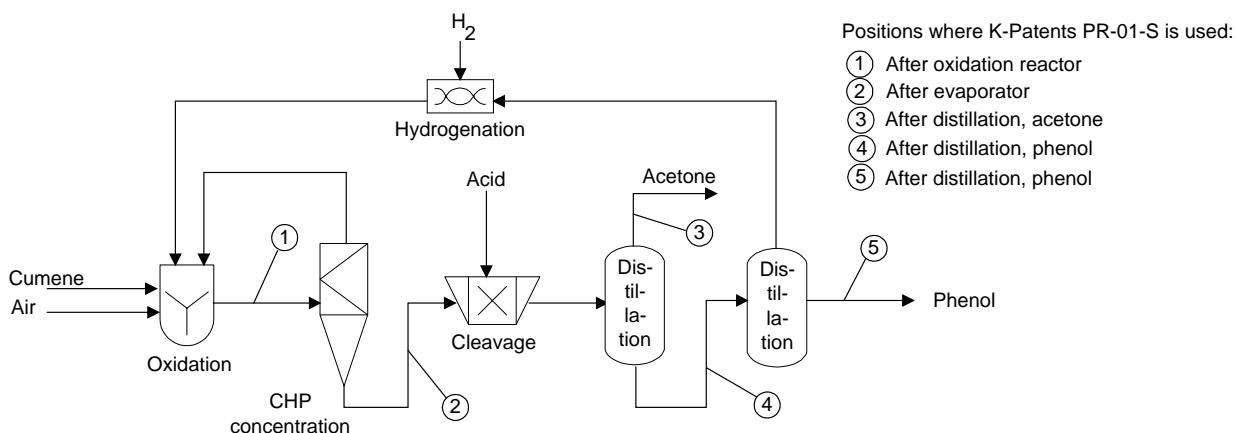

Phenol (C₆H₅OH)
Cumene Hydroperoxide (C₆H₅C(CH₃)₂O₂H)
Acetone (CH₃COCH₃)

Soluble in

water, alcohol, benzene, chloroform, ether

Typical end products/ uses

Phenolic resins, bisphenol A, caprolactam, alkyl-phenols, nylon, dyes, pharmaceuticals, perfumes

Chemical curve: R.I. per Conc%b.w.

Phenol

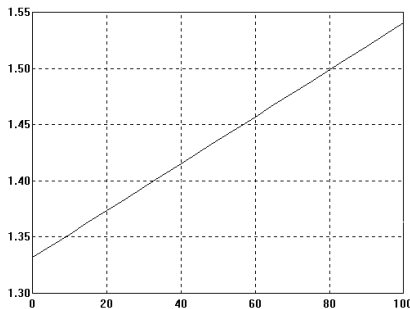

R.I. Ref. temp 20°C

Cumene hydroperoxide:

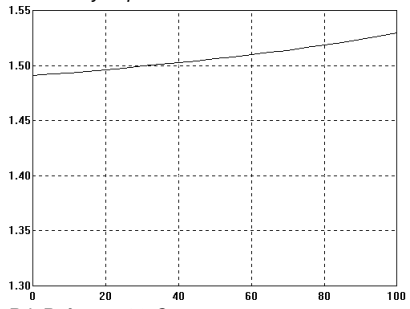

R.I. Ref. temp 20°C

Introduction

Phenol (C₆H₅OH) is a white, crystalline mass. It has a distinctive sweet, tarry odor, and burning taste.

Application

The cumene oxidation route is the leading commercial process of synthetic phenol production, accounting for more than 95% of phenol produced in the world. The remaining 5% is manufactured by toluene-benzoic acid process.

Cumene process

A typical phenol plant can be divided into two main areas. In the reaction area, cumene is oxidized to form cumene hydroperoxide (CHP). The cumene hydroperoxide is concentrated and the concentrated solution is fed to the cleavage reaction, which is carried out in the presence of an acid catalyst (e.g. sulphuric acid). The by-products of the cleavage reactions as well as the catalyst must be neutralized and extracted to avoid corrosion problems downstream.

The recovery area of the plant employs fractionation to recover and purify the phenol and acetone products. Also in this section the

alpha-methylstyrene (AMS) is recovered and may be hydrogenated back to cumene or recovered as AMS product. The hydrogenated AMS is recycled as feedstock to the reaction area.

Installation

K-Patents Process Refractometer, PR-01-S is used to measure CHP concentration after the reactor and in the evaporator for security purposes and for optimization of the process. Typical measurement range after reactor is 10-50% and temperature 100°C (212°F). After evaporator the numbers are 90% and 90°C (194°F) respectively. The K-Patents PR-01-S is also used to measure phenol and acetone concentration.

The EX/FM approved intrinsically safe sensor is required.