

BEVERAGE	
APPLICATION NOTE	2.04.01
JUICE EVAPORATION	

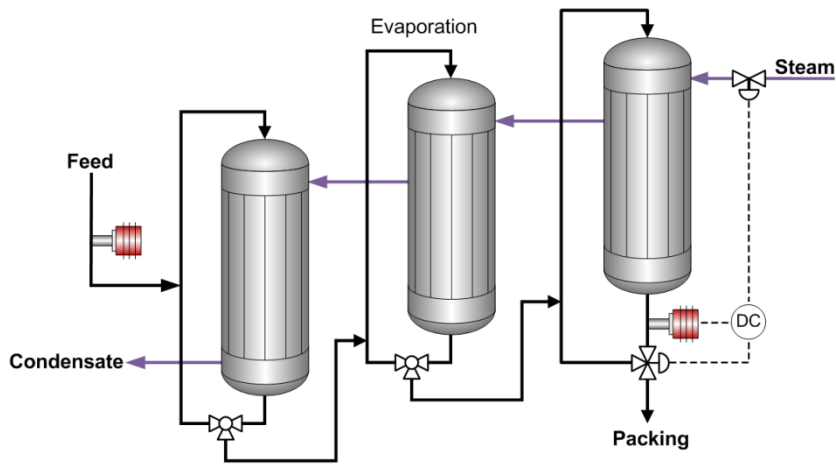

JUICE CONCENTRATE

Typical end products

Fruit and vegetable juice concentrate (apple, orange, grapefruit, pineapple, tomato, passion fruit, mango, carrot, grape, cherry, cranberry, guava, pomegranate etc.)

Chemical curve: R.I. per BRIX at Ref. Temp. of 20°C

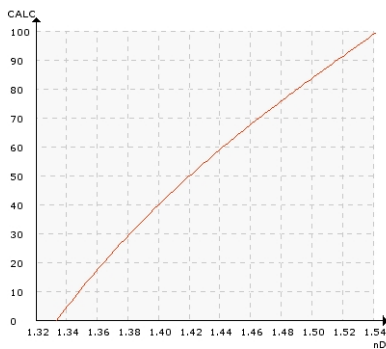

Introduction

Fruit juice concentration requires the partial removal of water content so that all the solid components such as fruit sugars, minerals and vitamins are left in a more concentrated solution. The purpose of concentration is to ensure longer storage life and easier transportation.

Application

After juice extraction, screening and centrifugal purification, the juice goes to a primary tank. At this stage, the juice concentration is inconsistent, varying from 9 to 12 Brix. The concentration depends on various factors such as fruit quality and annual rainfall. The juice is then fed to the evaporation plant.

For fruit juice concentration, a three-stage falling film evaporation plant is commonly used. The evaporators have a constant boiling rate. In the evaporation process, the concentration value is typically increased from 10 to 65 Brix.

Installation

The K-Patents Sanitary Refractometer PR-23-AC is mounted on the evaporator outlet. It provides a signal to a controller regulating the Brix value by varying the evaporator inlet flow.

If the Brix value increases, the valve allows a product flow rate increase through evaporators. This brings the Brix value back to the set-point. Typical measurement range is 30-80 Brix.

Instrumentation



Description

K-Patents Sanitary Compact Refractometer PR-23-AC for small pipe line sizes of 2.5 inch and smaller.

The PR-23-AC sensor is installed in the pipe bend. It is angle mounted on the outer corner of the pipe bend directly, or by a flow cell using a 3A Sanitary clamp or Varivent® connection.

Measurement range:

Refractive Index (nD) 1.3200 – 1.5300, corresponding to 0-100 Brix.

BEVERAGE	
APPLICATION NOTE	2.04.01
JUICE EVAPORATION	